

CLIMOS 100/150 DC

COMFORT VENTILATION 'MVHR' UNIT FOR INSTALLATION IN CEILING VOID

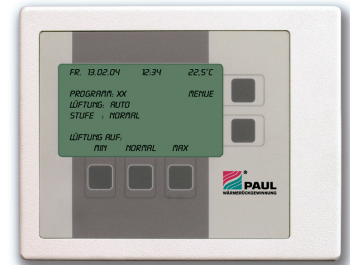
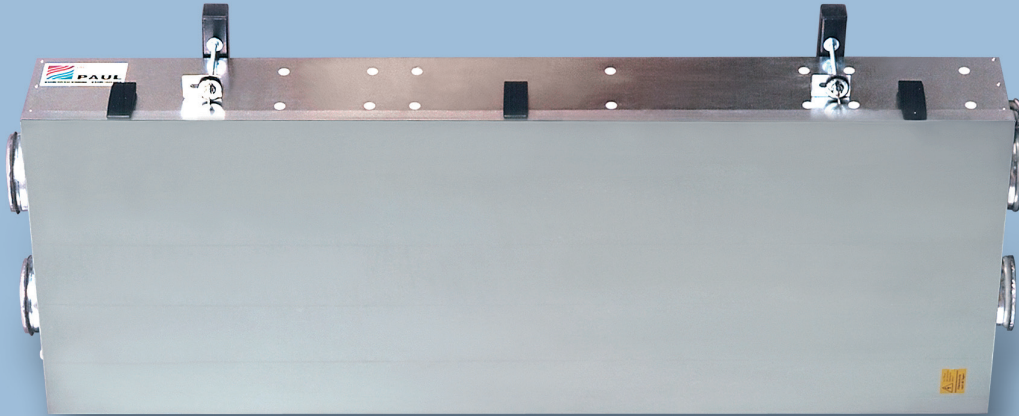

Programmer (external)
for automatic control
L x W x D (mm): 158 x 125 x 32

- 1 control cable
- 2 angle bracket (4x)
- 3 snap locks (3x) – hinges on opposite side
- 4 condensate drain
- 5 cover panel

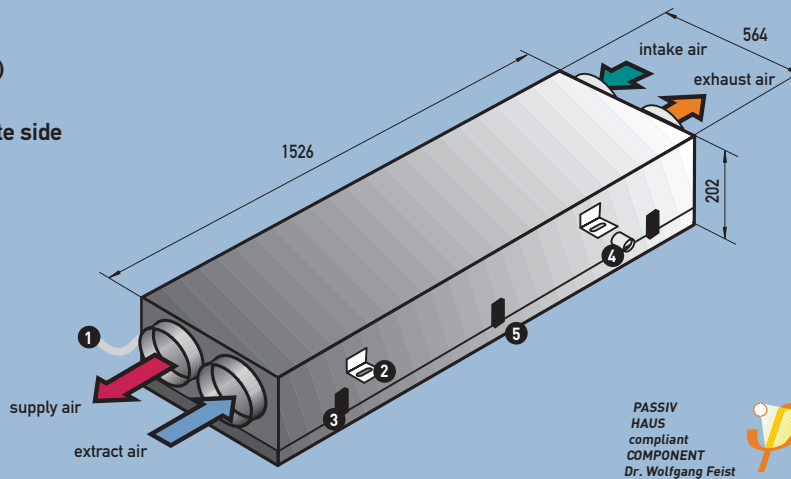

Design variants

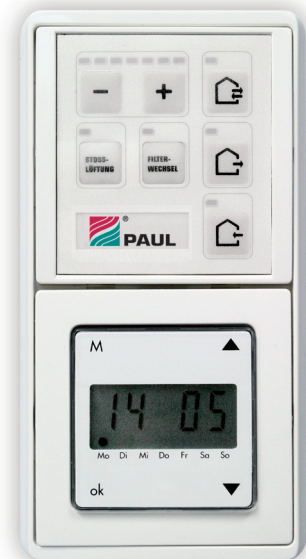
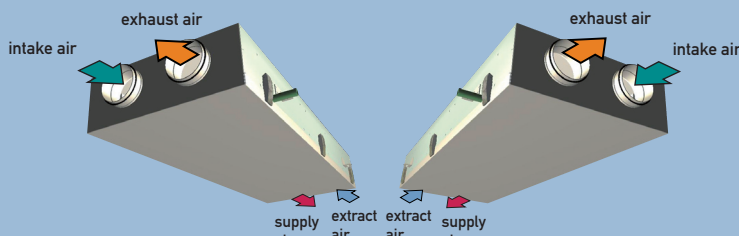

Membrane keypad
for manual control
with week timer matching the
PEHA switch programme (option)

PRODUCT DESCRIPTION

The Comfort Ventilation unit climos is available in two specifications: climos 100 DC and climos 150 DC. It was specifically developed for hidden installation in false ceilings voids. Like all mechanical ventilation heat recovery units by PAUL, it features the highly efficient counter-flow channel-type heat exchanger (protected by German and European patents). Due to its flat design and its different specifications, the unit is particularly well suited for the renovation of large flats, offices etc.

The concealed installation in false ceilings allows renovated structures to be provided with a comfortable ventilation system in a space-saving and visually preferable manner. For this type of application, Paul Wärmerrückgewinnung GmbH can supply a service hatch tailored to the specific needs of the customer.

Air flows can be varied by means of two energy-saving electronically commutated 48 VDC radial fans. The MVHR unit can be equipped with a manual control or an automatic control, depending on customer requirements. The manual control is a membrane keypad, which can be integrated into the PEHA switch system. The membrane keypad provides 7-step air flow control, balancing, airing out, supply-only or extract-only (summer ventilation), filter watchdog function and automatic frost protection. An additional boost button and a week timer can be connected, and the unit can be set-up to work with fireplaces (optional extra). The automatic mode allows the air flow rate to be adjusted in 3 steps. Fan power of the 3 steps can be varied in 1% increments. Moreover, the freely programmable control system makes it possible to preset operating times for ventilation at the desired rate; 8 timing programs are available. Alternatively the 3 fan speeds can also be controlled by hand. The standard functions include filter monitoring, intake/exhaust balancing, frost protection for downstream hot water back-up duct heater, connection of several boost switches and a special standby circuit with a power input less than 2 W. Possible options are: constant-flow control (e.g. for fireplace mode), regulating either a ground to air heat exchanger valve or a ground to brine to air frost protection, controlling an electric frost protection heater, a back-up duct heater, or a heating circuit pump, and connection of several programmers. The Paul MVHR unit is a fully soundproofed and heat-insulated design with no thermal bridges. The intake air is cleaned via a G4 filter or, optionally, F8 pollen filter. On the extract side, a G4-class filter protects the MVHR unit from contamination.

climos 100/150 DC

Unit dimensions:
Controller dimensions:
incl. optional frost prot.
and back-up heaters:
(for automatic control)

Installation:

Place of installation:

Duct connections:

Condensate:

Material:

Weight:

Filters:

Electrical connection:

Cable lengths:

Control:

Protection:

Ventilators:

Power input/flow/
available pressure:

Heat recovery rate:

Sound pressure level:
acc. to DIN 3743-1
(3-m distance in dB[A])

Temperature range of
heat exchanger:

Summer operation:

Frost protection:

Back-up heating:

Information:

TECHNICAL DATA

H x W x D [mm]: 1526 x 564 x 202
L x W x D [mm]: 340 x 300 x 80

L x W x D [mm]: 340 x 300 x 140

horizontal, sloping (2%) towards condensate
drain: condensate trap

frost free, preferably > 10°C

4 x air 125 mm in dia.

¾" hose connection

Housing: galvanised steel plate, up to
40 mm heat insulation,
no thermal bridges, soundproofed
Heat exchanger: plastic

45 kg

intake air: G4 or F8 (pollen filter),
extract air: G4

230 V, 50 Hz: ready for connection –
no cable

- power cord (230 V): by customer
- MVHR unit to control unit: 3 m
- automatic control to programmer:
max. 15 m (by customer)

- manual control with membrane keypad,
or
- automatic control with programmer
(climos 150 DC only)

IP 41 (unit), IP 20 (control)

2 48VDC radial fans

see charts 1 and 2

approx. 85 to 98% (climos 100 DC)
approx. 80 to 95% (climos 150 DC)

climos 100 DC				
Step	1	3	5	7
Lp	19	22	25	28

climos 150 DC				
Step	1	3	5	7
Lp	23	27	32	33

can be used between -20°C and 40°C

supply-only or extract-only
(manual control)

- continuous slowing down of supply air
fan¹⁾ in manual control, or
- optional frost protection heater, or
- optional ground to air heat exchanger

¹⁾ with optional fireplace mode

- hot water duct heater as external unit, or
- electric duct heater as external unit

Subject to change in the interest of
technical progress.

Distributed by:

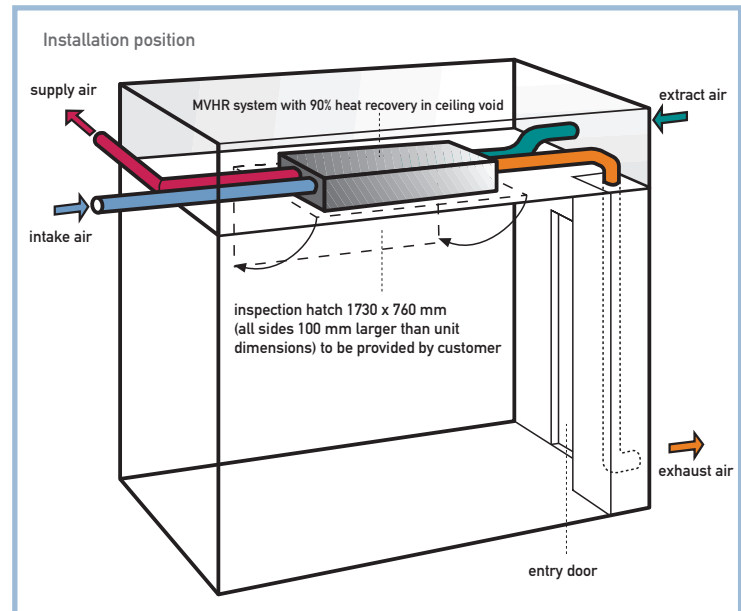

Characteristic of climos 100 DC

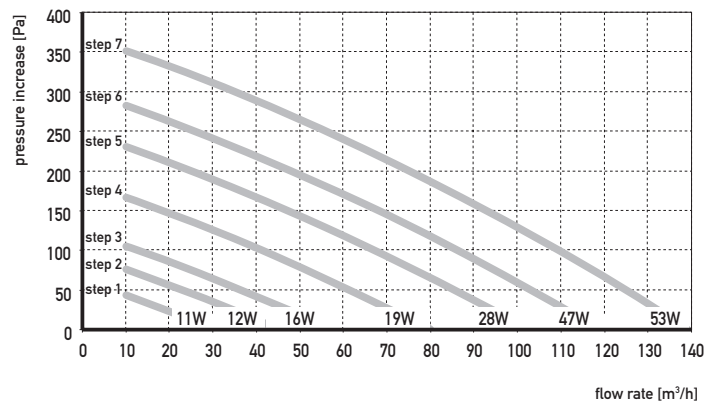

Chart 1: Characteristics for flow rate, externally available pressure and power input

Characteristic of climos 150 DC

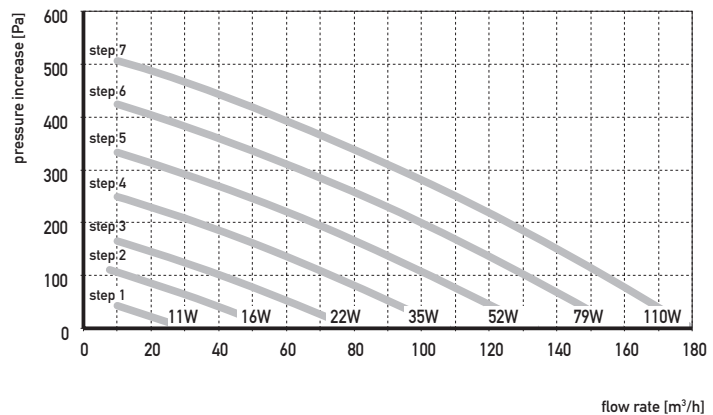

Chart 2: Characteristics for flow rate, externally available pressure and power input

- Environment award
- Innovation awards
- European and German patents
- Product of the Year award
- First Passiv Haus certified MVHR
system
- Environment Oscar award
- INTEC award for Saxony

PAUL Comfort Ventilation obtained innovation awards both on the German state and Saxon regional levels, and received the German Environment Award (European-wide competition), as well as the Product of the Year and Environment Oscar awards.

PAUL offers equipment for controlled residential ventilation with efficiencies of up to 99% – groundbreaking in the industry.

Our motto is "New ideas in ventilation" – for fresh and healthy air in homes with energy saving systems for safeguarding the integrity of the environment.



Paul Wärmerückgewinnung GmbH · Vettermannstraße 1-5 · D-08132 Mülsen · Tel. +49(0)37601 390 - 0 · Fax +49(0)37601 258 45
E-Mail: info@paul-lueftung.de · Internet: www.paul-lueftung.net